

MICRO INVERTER

■ ROHAN B. REBELLO

A simple low-power inverter circuit is described here. It converts 12V DC into 230V AC. It can be used to power very light loads like night lamps, cordless telephones, etc, and can be modified into a powerful inverter by adding MOSFETs. This circuit has two stages – battery charger section with cut-off and an indicator to show battery charge and inverter circuit.

Charging circuit is built around IC1 (LM317) (Fig. 1). When mains 230V AC is available, IC1 provides gate voltage

through diode D1 (1N4007) and SCR1 (TYN616) and starts charging the battery. For output voltage setting use preset VR1.

The battery indicator and inverter circuit is shown in Fig. 2. The battery level checking system is built around transistors T1 (BC547) and T2 (BC547) along with some discrete components. When the battery is charged (say more than 10.50V), LED1 glows and piezo-buzzer does not sound. On the other hand, when battery voltage goes below (say less than 10.50V), LED1 stops glowing and piezo-buzzer sounds, indicating that the battery has been

discharged and needs re-charging for further use.

The inverter is built around IC2 (CD4047). It is wired in an astable multi-vibrator operating at a frequency of around 50 Hz. The Q and Q outputs of IC2 directly drive power MOSFETs (T3 and T4). The two MOSFETs are used in push-pull type configuration. The inverter output is filtered by capacitor C1.

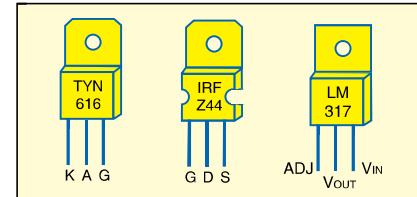

Fig. 3: Pin configurations of TYN616, IRFZ44 and LM317

Assemble the circuit on a general-purpose PCB and enclose it in a suitable metal box. Refer Fig. 3 for pin configurations before mounting components on the PCB. Mount the transformer on the chassis and the battery in the box using supporting clamps. Use suitable heat sinks for MOSFETs. The circuit can be used for other applications as well to deliver higher power with the help of high current rating transformer and additional MOSFETs. ●

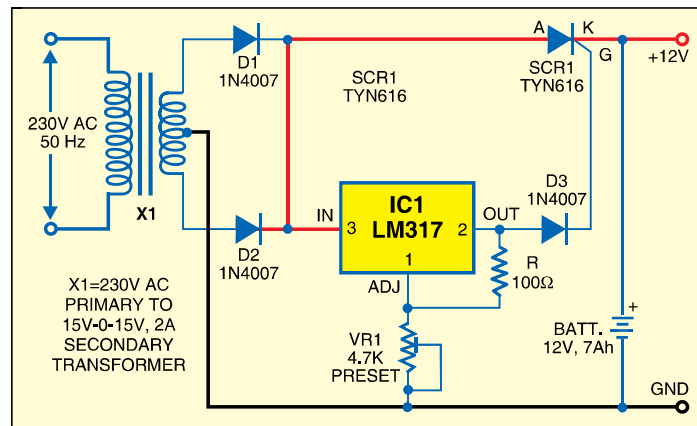

Fig. 1: Battery charger

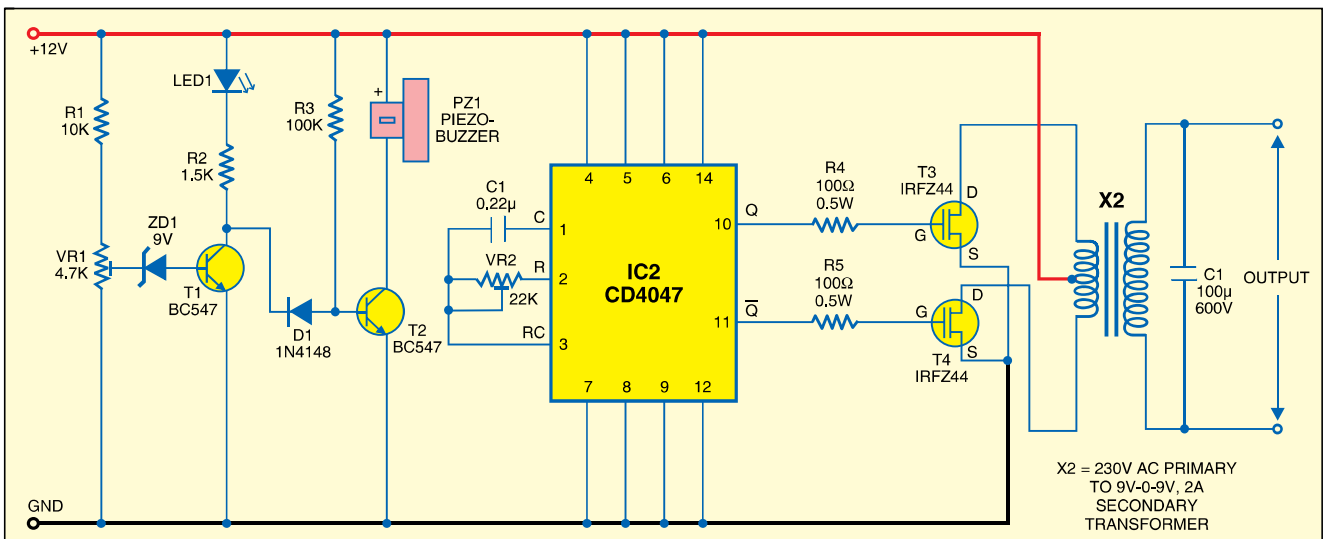

Fig. 2: Simple inverter